

BOLZONI S.p.A.
29027 Casoni di Podenzano
(Piacenza) Italy
Tel: +39-0523-55 55 11
Fax: +39-0523-52 40 87
Internet: www.bolzoni-auramo.com
E-mail: sales.it@bolzoni-auramo.com

AURAMO OY
P.O.Box 78 (Valimotie 22)
01511 Vantaa - Finland
Tel: +358-9-82 931
Fax: +358-9-87 01 037
E-mail: sales.fi@bolzoni-auramo.com

BOLZONI AURAMO LTD
Unit 10, Taurus Park
Europa Boulevard
West Brook
Warrington Cheshire WA5 7ZT
United Kingdom
Tel: +44-1925-62 45 70
Fax: +44-1925-62 45 78
E-mail: sales.uk@bolzoni-auramo.com

BOLZONI AURAMO RENTAL LTD
Unit 10, Taurus Park
Europa Boulevard
West Brook
Warrington Cheshire WA5 7ZT
United Kingdom
Tel: +44-1925-62 45 70
Fax: +44-1925-62 45 79
E-mail: rental@bolzoni-auramo.com

BOLZONI AURAMO GmbH
Mühlenstr. 74
41352 Korschenbroich - Germany
Tel: +49-2161-999-36-0
Fax: +49-2161-999-36-99
E-mail: sales.de@bolzoni-auramo.com

BOLZONI AURAMO SARL
Rue Avogadro
Technopôle de Forbach-Sud
57600 Forbach - France
Tel: +33-3-87 84 65 40
Fax: +33-3-87 84 65 45
E-mail: sales.fr@bolzoni-auramo.com

BOLZONI AURAMO S.L.
Polig. Industrial Riera de Caldes
C/ dels Basters, 12-14 -
Apdo. 62,
08184 Palau solità i Plegamans
(Barcelona) Spain
Tel: +34-938-648-633
Fax: +34-938-648-350
E-mail: sales.es@bolzoni-auramo.com

Lisboa Office - Portugal
Tel / Fax: +351-212-902551
Tel móvil: +351-917-884976
E-mail: lsilva@bolzoni-auramo.com

BOLZONI AURAMO AB
P.O.Box 172
80103 Gävle - Sweden
Tel: +46-26-64 72 30
Fax: +46-26-64 72 35
E-mail: sales.se@bolzoni-auramo.com

BOLZONI AURAMO S.r.l.
S.S. 16 Km 770+580
70052 Bisceglie (BA) Italy
Tel: +39-080-39 51 437
Fax: +39-080-39 51 393
E-mail: sales.it@bolzoni-auramo.com

BOLZONI AURAMO POLSKA Sp. z o.o.
Ul. Wojciechowska 5A
20-704 Lublin
Poland
Tel: +48-81-44 65 491
Fax: +48-81-44 65 490
E-mail: sales.pl@bolzoni-auramo.com

BOLZONI AURAMO BV
Waterbeemd 6a
5705 DN Helmond
Industrieterrein nr. 8955
The Netherlands
Tel: +31-492-50 97 77
Fax: +31-492-38 28 44
E-mail: sales.benelux@bolzoni-auramo.com

BRUDI BOLZONI AURAMO INC.
17635 Hoffman Way
Homewood, Illinois 60430 - U.S.A.
Tel: +1-800-358 54 38 (USA only)
Tel: +1-708-957 88 09
Fax: +1-708-957 88 32
E-mail: sales.us@bolzoni-auramo.com
www.bba-usa.com

BRUDI BOLZONI AURAMO Ltd.
90C Brunswick Blvd
Dollard-des-Ormeaux, Quebec H9B 2C5 -
Canada
Tel: +1-800-685-78 71 (Canada only)
Tel: +1-514-685-78 71
Fax: +1-514-685-52 38
E-mail: sales.ca@bolzoni-auramo.com
www.bba-usa.com

BOLZONI AURAMO S.A.
Av. Isidora Goyenechea 2925
Office 103
Las Condes
Santiago - Chile
Tel: +56-2-374 09 99
Fax: +56-2-374 03 68
E-mail: sales.cl@bolzoni-auramo.com

BOLZONI AURAMO (Pty) Ltd.
P.O.Box 7198
Baulkham Hills DC
NSW 2153 - Australia
Tel: +61-2-9659-22 24
Fax: +61-2-9659-22 25
E-mail: sales.au@bolzoni-auramo.com

RT Equipment Limited
58, Hobill Avenue
Manukau City,
Auckland - New Zealand
Tel: +64-9-262 07 21
Fax: +64-9-262 05 67
E-mail: christ@rtforkhoist.co.nz

BOLZONI AURAMO SOUTH AFRICA (Pty) Ltd.
P.O. Box 915
Benoni 1500
South Africa
Tel: +27-11-421-07 38
Fax: +27-11-421-52 08
E-mail: sales.za@bolzoni-auramo.com

**BOLZONI AURAMO Shanghai Forklift
Truck Attachment Co. Ltd**
No.11 Plant, Zone B,
No. 206 Peikun Rd.,
Minhang District,
Shanghai 201111
P.R. China
Tel: +86-21-640-930-50
Fax: +86-21-640-930-60
E-mail: raining_sh@sohu.com

AURAMO BALTIC OÜ
Suur-Sõjamäe 10
Tallinn 11415 - Estonia
Tel: +372-6-10 11 14
Fax: +372-6-10 11 58
E-mail: sales.ee@bolzoni-auramo.com

MCGOWAN ENGINEERING LTD
Lightburn Road
Cambuslang - Glasgow G72 7XS -
Scotland (U.K.)
Tel: +44-141-641-3648 /2359
Fax: +44-141-641-51 47
E-mail: info@mcgowaneng.co.uk

CEMAT s.r.o.
Ul. CSA 196
735 51 Bohumin-Pudlov
Czech Republic
Tel +420-596-013-541
Fax +420-596-013-522
E-mail: cemat@cemat.cz

CEMAT s.r.o.
Sucianska cesta 31
036 08 Martin
Slovak Republic
Tel +421-43-430-25-63
Fax +421-43-430-25-62
E-mail cemat@cemat.sk
www.cemat.sk

MAR-GO KFT. Ltd.
Fehérvári út 63-65
2030 Érd - Hungary
Tel. +36-24-530 201
Fax: +36-24-530 200
E-mail: stefano@mar-gokft.datanet.hu

EUROLIFT Pty. Ltd.
2/81 Harrison Road
Dudley Park 5008
South Australia
Tel: +61-8-83 46 35 55
Fax: +61-8-83 46 94 22
E-mail: info@eurolift.com.au

**INSTANT MATERIALS HANDLING
SDN BHD**
No. 23, 1st Floor Jalan TSB 10A
Taman Industri Sungai Buloh,
47000, Sungai Buloh, Selangor
Malaysia
Tel: +60-3-6157 28 96
Fax: +60-3-6157 07 81
E-mail: imhsb@tm.net.my

**ADJL INTERNATIONAL
(TAIWAN) LTD.**
4-6Fl., No.28, Sec. 3,
Chung San North Rd.,
Taipei - Taiwan
Tel: +886-2-2668-67 68 / 69 / 70
Fax: +886-2-2668-67 73
E-mail: adjl@saturn.seed.net.tw

**PT AURAMO Mekanika
Tradindo**
JL Agung Perkasa 10/11
Sunter Agung Podomoro
Jakarta 14350 - Indonesia
Tel: +62-21-65 21 247
Fax: +62-21-65 12 378
E-mail: sales.id@bolzoni-auramo.com

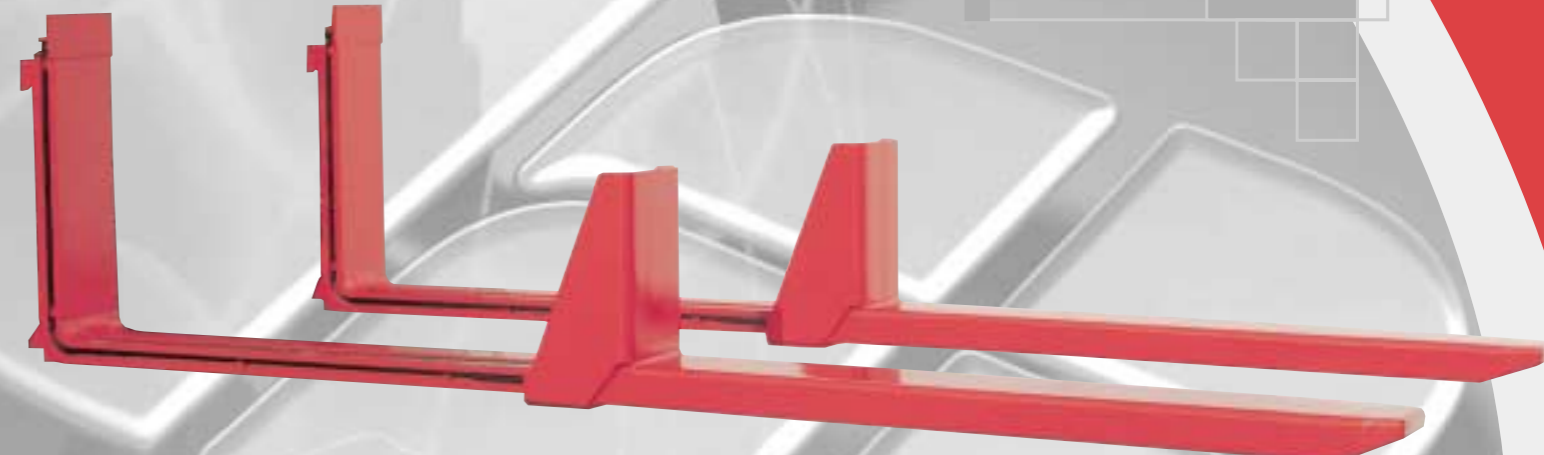

reach forks easy reach

REACH FORKS

The "Easy Reach" forks produced by Bolzoni Auramo are an effective solution to save time during handling of loads. Optimising available space and time are essential factors for any organisation involving transportation of goods.

The main benefits are:

FS MODELS

- Loading and unloading of vehicles from one side, gives a remarkable saving on time;
- Handling pallets in double deep racking, or reaching over obstacles;
- A pallet stop allows accurate positioning of the loads;
- The flow divider provides synchronized movement of the forks.

FD MODELS

- Two pallets at a time reduces the handling time by 50%;
- Capable of handling bulky loads;
- Pallets of different sizes can be catered for;
- Metal plates on the top of the fixed element ensures that the load remains stable on the forks.

Double deep stacking achieves remarkable space saving particularly when combining the "Easy Reach" forks with a reach truck that can work in narrow aisles. Hydraulically powered "Easy Reach" forks maximises the manoeuvrability of the truck when the forks are in the retracted position.

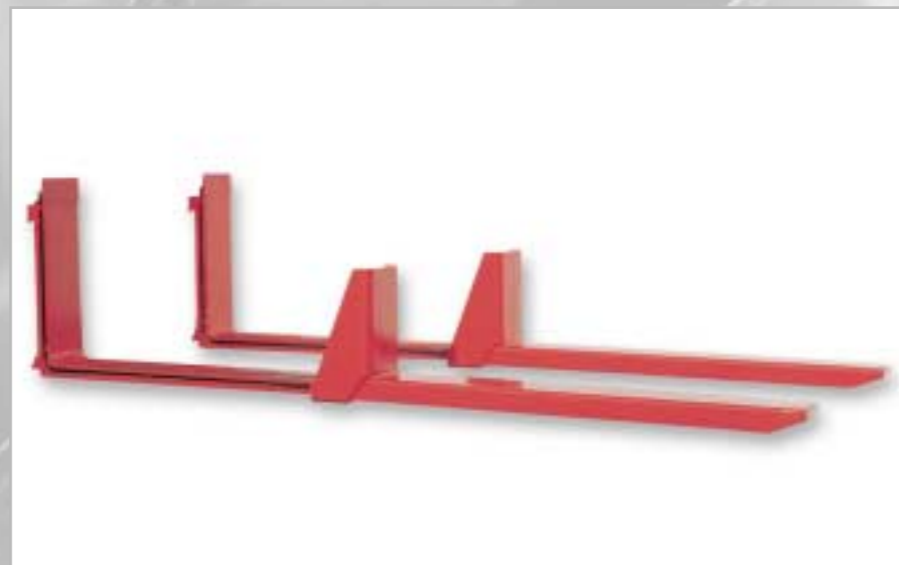
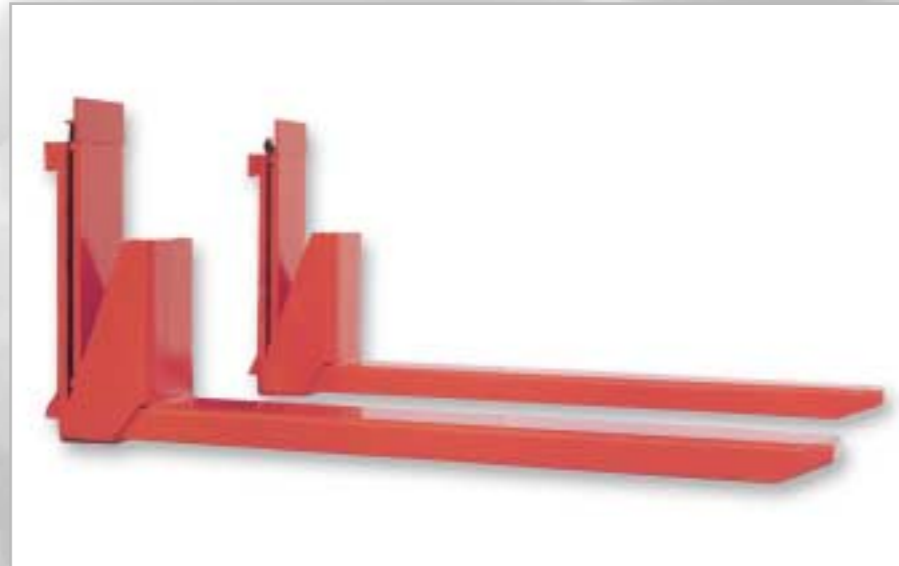

TECHNICAL FEATURES

COMPETITIVE INNOVATION

During the design of the "Easy Reach" forks, Bolzoni Auramo has incorporated unique features with real advantages when comparing similar products.

- **SMOOTHNESS.** Friction has been reduced to a minimum by the use of two roller sliding tracks in special steel fixed to the mobile element. The use of special nylon pads to both upper and lower parts of the fixed element eliminates metal to metal contact.
- **STRENGTH.** Having a single cylinder fitted to the fixed element retains a stronger structure.
- **EASE OF ECONOMICAL MAINTENANCE,**
 - An independent, replaceable cylinder allows a quick low cost maintenance solution.
 - Steel pipe hydraulic feed in the fixed part is accessible by simply extending the forks.
 - Ease of dismantling the mobile part by the removal of a retaining pin.
- **SYNCHRONIZED MOVEMENT.** A flow divider on the double reach models equalises the speed of the two forks to maintain stability and efficiency during the handling of loads.

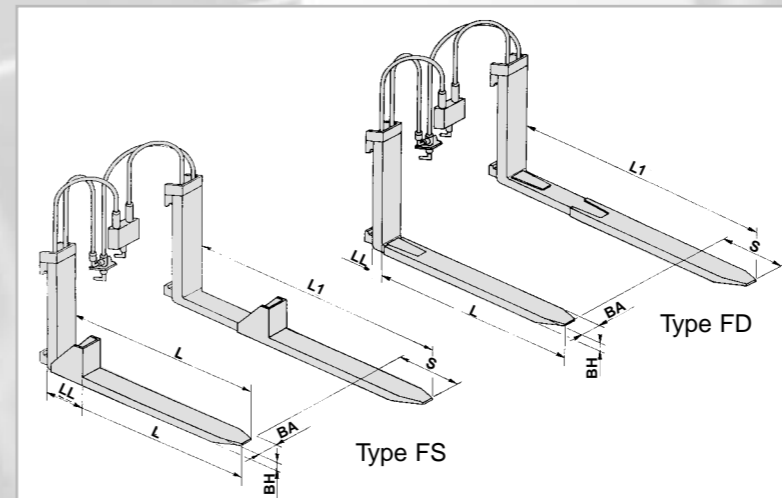

Reach forks for loads in duple depth - 1 hydraulic function

Type	Capacity/ Load Centre	Capacity/ Load Centre	Mounting Class	Length Closed	Length Extended	Stroke	Fork Size	Weight	Thickness	CG Closed	CG Extended
	Q1 kg/mm	Q2 kg/mm	FEM	L mm	L1 mm	S mm	BA X BH mm	W kg	LL mm	CG1 mm	CG2 mm
FS20EOA	2000 / 750	850 / 1750	II	1350	2350	1000	160 x 62	260	200	450	725
FS26EOB	2600 / 750	1100 / 1750	III	1350	2350	1000	160 x 62	270	200	450	725

Extension forks for 2 pallets - 1 hydraulic function

Type	Capacity/ Load Centre	Capacity/ Load Centre	Mounting Class	Length Closed	Length Extended	Stroke	Fork Size	Weight	Thickness	CG Closed	CG Extended
	Q1 kg/mm	Q2 kg/mm	FEM	L mm	L1 mm	S mm	BA X BH mm	W kg	LL mm	CG1 mm	CG2 mm
FD20EOA	2000 / 750	1250 / 1200	II	1350	2350	1000	160 x 62	250	55	450	725
FD26EOB	2600 / 750	1650 / 1200	III	1350	2350	1000	160 x 62	260	55	450	725

Note

- Q1 = capacity when closed
- Q2 = capacity at maximum extension
- Models FS are equipped with flow divider valve for synchronized fork movement (recommended also for model FD).

On request

- Different stroke and dimensions.
- Load backrest.